



**LISTED**  
DELUGE VALVE  
EX16301



**Flow-age**®



**DELUGE  
VALVE**

**FLOW-TEK**

**VALVES & CONTROLS INC**

Going Beyond the Technology

[www.flowtekvalves.com](http://www.flowtekvalves.com); [www.delugecontrolvalve.com](http://www.delugecontrolvalve.com)

[www.flowagevalves.com](http://www.flowagevalves.com); [www.controlvalveindia.com](http://www.controlvalveindia.com)

E-mail : [info@flowagevalves.com](mailto:info@flowagevalves.com), [hemal21386@gmail.com](mailto:hemal21386@gmail.com)



## History

The story of **Flow-Tek Valves & Controls Inc** began more than 20 years ago, when founder **Mr. K.B. Patel** decided to expand his existing machine shop to begin designing and manufacturing control valves in Ahmedabad, India. He established his company with a vision of commitment to quality and reliability.

Since its modest beginning, **Flow-Tek Valves & Controls Inc** has maintained that vision while becoming a worldwide leader alongwith India in the valve industry.

## Mission Statement

To be recognized as one of the world's most trusted and innovative manufacturer of fire protection equipments by providing our customers highest quality products that combine performance and advanced technology with value pricing achieving 100% customer satisfaction.

## Vision

Continue to offer customers top quality products to meet or exceed customer's needs.

We focus on:

\* **Customer service** \* **Product quality** \* **Product design** \* **Delivery reliability**

## Values

For more than 20 years, **FLOW-TEK VALVES & CONTROLS INC** Control Valves has maintained a family-like atmosphere in the workplace that goes hand in hand with family values.

Company founder **Mr. K. B. Patel** had a mission to produce a quality product in a quality work environment.

Today his son **Mr. Hemal Patel** and **Mr. Jatin Patel** continue that mission and uphold several important values both in the workplace and among their client base.

## Registration & Certification

**FLOW-TEK VALVES & CONTROLS INC** is dedicated to quality, as evidenced by their **ISO Quality System**, **UL listings**, **IBR approvals**, **NSIC registered**, **CE**.

The company is also dedicated to continual improvement, as proven by their in-house continual improvement department and constant pursuit of new industry approvals.

## UL CERTIFICATE

### CERTIFICATE OF COMPLIANCE

**Certificate Number** 20171031-EX16301  
**Report Reference** EX16301-20140811  
**Issue Date** 2017-OCTOBER-31

**Issued to:** FLOW-TEK VALVES & CONTROLS INC  
Plot172-173  
Road-4, G.I.D.C. Kathwada  
Ahmedabad Gj 382430, INDIA

**This is to certify that  
representative samples of**

SPECIAL SYSTEM WATER CONTROL VALVES, DELUGE  
TYPE

Models ACV FTV 100 in the 2, 2 1/2, 3, 4, 6, 8, and 10 inch.  
nominal sizes with flanged ends for use in horizontal and  
vertical position for a rated working pressure not to exceed  
250 psig.

Have been investigated by UL in accordance with the  
Standard(s) indicated on this Certificate.

**Standard(s) for Safety:** UL 260, Dry Pipe and Deluge Valves for Fire-Protection  
Service.

**Additional Information:** See the UL Online Certifications Directory at  
[www.ul.com/database](http://www.ul.com/database) for additional information

Only those products bearing the UL Certification Mark should be considered as being covered by UL's  
Certification and Follow-Up Service.

Look for the UL Certification Mark on the product.



Bruce Mahrenholz, Director North American Certification Program

UL LLC

Any information and documentation involving UL Mark services are provided on behalf of UL LLC (UL) or any authorized licensee of UL. For questions, please  
contact a local UL Customer Service Representative at <http://ul.com/aboutul/locations>



**(UL LISTED) DELUGE VALVE [FILE NO.EX16301]  
MODEL - ACV FTV 100**



**INDEX**

1.	TECHNICAL DATA	3
2.	DESCRIPTION	4
3.	TRIM TYPES	6
4.	RESETTING PROCEDURE	7
5.	SYSTEM TESTING PROCEDURE	8
6.	INSPECTION AND MAINTENANCE	9
7.	VALVE ASSEMBLY	11
8.	VALVES DIMENSION	12
9.	SCHEMATICS	13
10.	GRAPH OF SPRINKLER HEIGHT LIMITATION	21
11.	GRAPH PRESSURE LOSS V/S FLOW	22
12.	DELUGE VALVE SKID	23
13.	ANGLE TYPE DELUGE VALVE	24

## TECHNICAL DATA

MODEL ACV FTV 100	:	Cast Steel ASTM A 216 WCB
NORMAL SIZE	:	50,65,80,100,150,200, & 250 NB
SERVICE PRESSURE	:	1.4 to 17 Bar (20 to 250 PSI)
THREADED OPENING	:	BSPT
MOUNTING	:	Vertical or Horizontal
FACTORY HYDROSTATIC TEST PRESSURE	:	31 Kg/sq.cm. (440 PSI)
FLANGE CONNECTION	:	ANSI B 16.5 # 150 RF (FF-Optional)
WET PILOT SPRINKLER HEIGHT LIMITATION	:	As per graph in the catalogue
NET WEIGHT WITHOUT TRIM	:	250 NB - 380 Kg 200 NB - 176 Kg 150 NB - 105 Kg 100 NB - 61 Kg 80 NB - 38 Kg 65 NB - 30 Kg 50 NB - 28 Kg
FINISH/PAINT	:	RAL 3000 (RED COLOR)/FIRE RED IS Confirm to IS5 Shade 536 to IS 2932
APPROVAL	:	UL Listed (50, 65, 80, 100,150, 200, & 250 NB)
ORDERING INFORMATION	:	1. Size of Valve 2. Flange specification 3. Valve trim vertical or horizontal 4. Trim type

## DESCRIPTION

**Deluge Valve** are used in conditions that call for quick application of large volumes of water and, for that reason, are often integral components in fire protection system.

**Deluge systems** deliver large quantities of water over a large area, in a relatively short period of time. They are commonly used in fixed fire protection systems whose pipe system is empty until the deluge valve distributes pressurized water from open nozzles or sprinklers.

**Deluge system** contain more components and equipment than wet pipe and dry systems. So for that matter they are more complex. Detection systems can include heat, smoke, ultraviolet (UV), or infrared (IR).

## VALVE OPERATION

FLOW-AGE Deluge Valve, Model ACV FTV 100 are diaphragm operated, Line Fluid Actuated, Globe Type Straight Pattern Valves. The valve remains closed when line fluid (water is loaded above the diaphragm in the cover chamber and valve opens fully, when line fluid (water) is emptied from the cover chamber.

Fire will activate the heat-sensitive automatic fire sprinkler in the sprinkler heads closest to the fire. The pressurized water/Air will flow from the activated sprinkler heads. Because the fire only activates the sprinkler heads closest to the fire, water damage is minimal. In fact, much less water is used when extinguishing a fire from a fire sprinkler than fire department extinguishment tools. When the fire sprinkler initiates, alarms will sound and continue sounding until the water flow is manually disabled.

## TRIM DESCRIPTION

The trims are functionally termed as Wet Actuation trim, Dry Actuation trim, Electric release System, Test and Alarm trim, Drain & Drip Trim as per the method of actuation of the deluge valve. The functionality of these trims is described below.

## 1. WET ACTUATION SYSTEM

Wet valve sprinkler systems are permanently charge with water and used to protect premises where temperatures are unlikely to fall below freezing point. They are designed to actuate operate electric, and/or hydraulic alarms when there is a steady flow of water into the system that is equivalent to the discharge rate of one or more sprinklers.

The type of sprinkler nozzle, its discharge pattern and flow rate are all pre-determined by the hazard classification of the of the type of fire risk involved. A typical Wet valve sprinkler system comprises of a control valve, sprinkler discharge heads and a dedicated water supply system.

## 2. DRY ACTUATION SYSTEM

Dry pipe system is a sprinkler system employing automatic sprinklers installed on a piping system containing air or nitrogen under pressure.

This dry pipe valve is used to hold back the water supply and to serve as the water / aire interface. It is designed so that a moderate amount of air pressure will hold back a much greater water pressure. When a fire occurs and enough heat is generated, one or more sprinklers will operate. The system's air pressure will then escape through the open sprinkler(s) and drop to a predetermined level to allow the dry pipe valve to open. Once the dry pipe valve opens, the water supply will be admitted into the sprinkler system piping to fill it and water will discharge from any sprinkler(s) that have operated. Dry pipe systems are used in environments that may be subject to freezing temperature.

## 3. ELECTRIC RELEASE SYSTEM

To actuate a Deluge valve electrically, a solenoid valve is provided to drain the water from the top chamber of the Deluge valve. A pressure switch is provided to activate an electric alarm, to shut down the desired equipment or to give "Tripped" indication of the Deluge valve. In addition to this a pressure switch can also monitor "Low air pressure" and "Fire condition" when used in dry pilot airline.

#### 4. TEST AND ALARM TRIM

This trim is supplied with a test valve is provided to test the normal operation of the sprinkler alarm bell. The sprinkler alarm can be supplied additionally, which bells on actuation of the Deluge valve.

#### 5. DRAIN AND DRIP TRIM

This consists of main and system drain valve in addition with drip valve.

### TRIM TYPES

The trims are designated as following.

WPT = Wet Pilot trim. DPT = Dry Pilot Trim.

#### 1. Type FTDLV-WPT and FTDLV-DPT

This type of trim is basic trim required to operate the deluge valve. A solenoid valve for electric remote actuation and pressure switch for sensing & annunciation are optional.

#### 2. Type FTDLV-WPT-DRN and FTDLV-DPT-DRN

This trim type is a combination of components of the ET trims along with the drip and drain trim. A solenoid valve for electric remote actuation and pressure switch for sensing & annunciation are optional.

#### 3. Type FTDLV-WPT-TST and FTDLV-DPT-TST

This trim type is a combination of components of the ET trims along with the test and alarm trim. In dry pilot trim, an actuator M-100 is provided with optional Pneumatic Reset Device. A solenoid valve for electric remote actuation and pressure switch for sensing & annunciation are optional.

#### 4. Type FTDLV-WPT-TST-DRN and FTDLV-DPT-TST-DRN

This trim type is a combination of components of the ET trim along with the test and alarm trim as well as the drip and drain trim. A solenoid valve for electric remote actuation and pressure switch for sensing & annunciation are optional.



TRIM MODEL NO.	DESCRIPTION	TRIM MODEL NO.
FTDLV-DPT	Basic Dry Pilot Trim	VERTICAL
FTDLV-WPT	Basic Wet Pilot Trim	VERTICAL
FTDLV-DPT-TST	Basic Dry Pilot + Test Alarm Trim	VERTICAL
FTDLV-WPT-TST	Basic Wet Pilot + Test Alarm Trim	VERTICAL
FTDLV-DPT-DRN	Basic Dry Pilot + Drip + Drain Trim	VERTICAL
FTDLV-WPT-DRN	Basic Wet Pilot + Drip + Drain Trim	VERTICAL
FTDLV-DPT-TST-DRN	Basic Dry + Test Trim + Drip + Drain Trim	VERTICAL
FTDLV-WPT-TST-DRN	Basic Wet + Test Trim + Drip + Drain Trim	VERTICAL
FTDLV-DPT	Basic Dry Pilot Trim	HORIZONTAL
FTDLV-WPT	Basic Wet Pilot Trim	HORIZONTAL
FTDLV-DPT-TST	Basic Dry Pilot + Test Alarm Trim	HORIZONTAL
FTDLV-WPT-TST	Basic Wet Pilot + Test Alarm Trim	HORIZONTAL
FTDLV-DPT-DRN	Basic Dry Pilot + Drip + Drain Trim	HORIZONTAL
FTDLV-WPT-DRN	Basic Wet Pilot + Drip + Drain Trim	HORIZONTAL
FTDLV-DPT-TST-DRN	Basic Dry + Test Trim + Drip + Drain Trim	HORIZONTAL
FTDLV-WPT-TST-DRN	Basic Wet + Test Trim + Drip + Drain Trim	HORIZONTAL

## RESETTING PROCEDURE

1. Close the upstream side stop valve provided below the deluge valve to cease the flow of water.
2. Open both the drain valves/ drain plugs and close when the flow of water has ceased.
3. Close the release device/replace the Sprinkler if release was through Sprinkler/ QB Detector.
4. Inspect and release if required, or close the section of the detection system subjected to "Fire condition".
5. In case of dry pilot detection system, open the air supply valve to build-up air pressure. Open the priming valve fully. Open the upstream side of the stop valve provided below the Deluge valve. No water should flow into the system.
6. Where priming shut off valve (optional) is provided for resetting, then the water need to be drained from upstream side of valve.

**NOTE:** The valve can be reset without undergoing above procedure, by just closing/replacing the release device as valve is auto reset type. The reset time may be long or cause vibration while closing depending on back pressure at the outlet of the valve.

## CAUTION

1. Do not close the downstream and upstream stop valves, while the system is in service.
2. The releasing device must be maintained in open position, when actuated, to prevent the deluge valve from closure if anti shut off valve is not provided.
3. While using a Deluge valve in the wet pilot system, the height and length of the wet pilot detection line is to be limited, as shown in the wet pilot sprinkler height limitation graph.
4. Do not connect the Sprinkler Alarm outlet drain line to close a common drain as it may create back pressure and Sprinkler Alarm may not function.
5. Deluge valve must have support to absorb sudden opening or closing vibration shock to the piping.
6. To avoid water damage, take precautions when opening the water supply main control valve, since water will flow from all open system valves.
7. The responsibility of maintenance of the protection system & devices in proper operating condition lies with the owner of the system.
8. Deluge Valve & its trim shall be maintained at a minimum temperature of 4°C, Heat tracing is not permitted.
9. Deluge Valve must be used in pressurized system.

## SYSTEM TESTING PROCEDURE

1. Keep the upstream side of the stop valve partially open. To avoid water flow to system side close the system side stop valve. This valve is to be kept in open position after the testing is completed.
2. Let any of the release devices to trip. This will result in sudden drop of water pressure in the deluge valve top chamber which in turn will open the deluge valve. Close the upstream side stop valve immediately.
3. Reset the valve as per the procedure given under heading "RESETTING PROCEDURE FOR THE DELUGE VALVE".

## INSPECTION AND MAINTENANCE

Installed system piping network must be flushed properly before placing the Deluge valve in service. A qualified and trained person must commission the system. After few initial successful tests, an authorized person must be trained to perform inspection and testing of the system. It is recommended to have regular inspection and test run of the system as per NFPA guideline or in accordance to the organization having local jurisdiction.

### 1. WARNING

Inspection and testing is to be carried out only by authorized and trained personnel. DO NOT TURN OFF the water supply or close any valve to make repair(s) or test the valve, without placing a roving fire patrol in the area covered by the system. Also inform the local security personnel and central alarm station, so that there is no false alarm signal. It is recommended to carry out physical inspection of the system at least twice in a week. The inspection should verify that all the control valves are in proper position as per the system requirement and that there are no damages to any component. The frequency of inspections must be increased in the presence of contaminated water supplies, corrosive/ scaling water supplies, and corrosive atmospheres.

### 2. NORMAL CONDITION

- A. All main valves are open and are sealed with tamper proof seal.
- B. Drain valves must be kept closed.
- C. No leak or drip is detected from the drip valve.
- D. All the gauges except the system side water pressure gauge, should show the required pressure.
- E. There should be no leakage in the system.

### 3. NORMAL CONDITION TEST

- A. The system should be checked for normal condition at least once in a week.
- B. Test the sprinkler alarm bell or electric alarm by turning the alarm test valve to the test position. The alarm should sound. This test should be carried out at least once in a week.

- C. Depress the drip valve knob. Significant accumulation indicates a possible seat leakage
- D. Conduct the water flow test as per the procedure of system testing at least once a month.

#### 4. PERIODIC CHECK

Conduct the water flow test by actuating few of the release devices provided in the system. Clean all strainer(s) and priming line restriction. This test is to be carried out at least once in three months.

### ABNORMAL CONDITION

#### 1. ALARM FAILS TO SOUND

- A. Check for any obstruction in the alarm test line, make certain that the sprinkler alarm is free to operate.
- B. If an electric alarm is provided, check the electrical circuitry to the alarm.

#### 2. FALSE TRIPS

- A. Check for clogging in priming line, restriction orifice check valve, priming valve & strainer.
- B. Leakage in the release system.
- C. The deluge air panel orifice clogged or low supply Pressure.

#### 3. LEAKAGE THROUGH THE DELUGE VALVE

- A. Damaged deluge valve seat or obstruction on the seat face by foreign object.
- B. Leakage in release system.
- C. Partly clogged priming line restriction orifice check valve.
- D. Low air pressure on release system line or leakage in release system

**VALVE ASSEMBLY**

**SIZE 50,65,80,100,150,200 & 250NB**

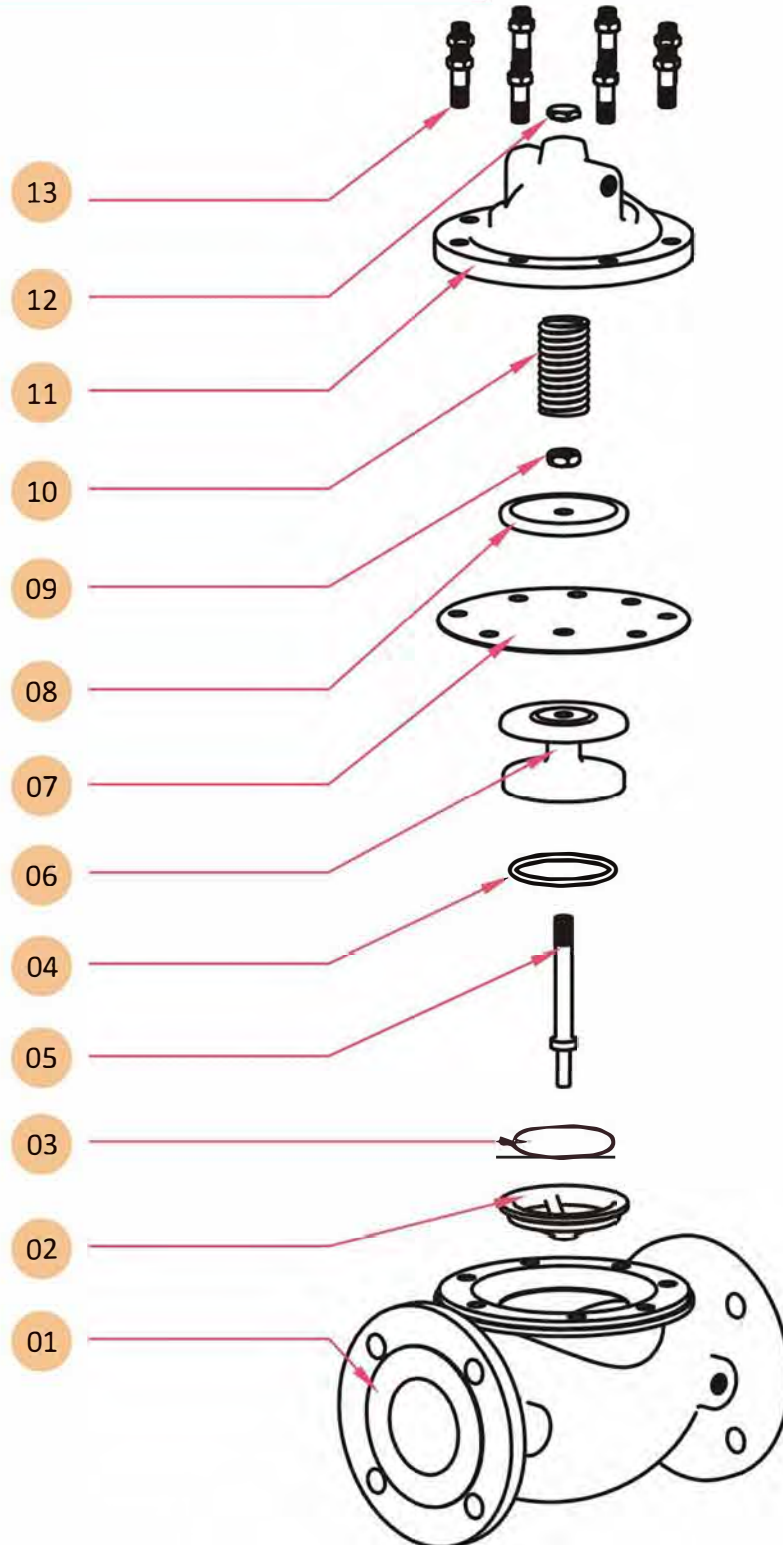

**VALVE DIMENSION**

**SIZE 50,65,80,100,150,200 & 250 NB**

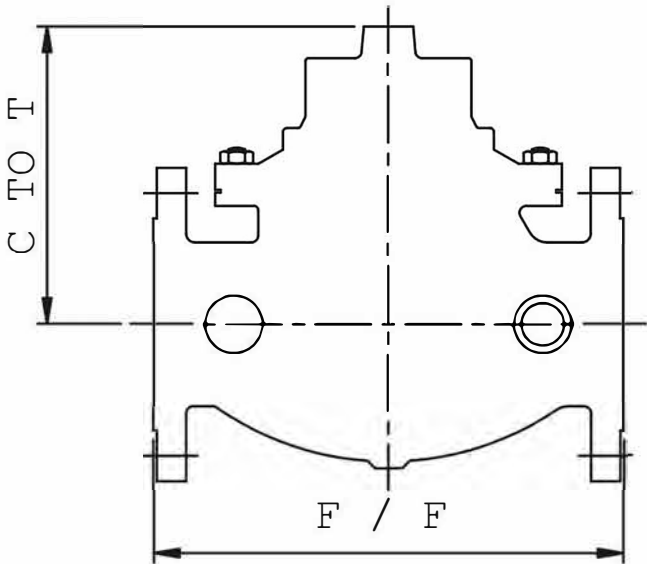

Valve Nominal Size	F/F	C TO T
50 NB	237.0	122.0
65 NB	279.5	144.0
80 NB	305.0	167.0
100 NB	381.0	228.0
150 NB	508.0	301.5
200 NB	645.0	395.0
250 NB	756.0	480.0

NO.	PART NAME	MATERIAL
01	BODY	ASTM A 216 GR. WCB
02	SEAT	ASTM A 351 GR. CF8
03	RETAINER PLATE	AISI 304
04	QUAD RING SEAT	BUNA-N
05	STEM	S.S 304
06	RETAINER	S.S 304
07	DIAPHRAGM	BUNA-N
08	DIAPHRAGM WASHER	S.S 304
09	STEM NUT	S.S 304
10	SPRING	SPRING STEEL/S.S 304
11	COVER	ASTM A 216 GR. WCB
12	PLUG	STEEL PLATED
13	STUD & NUT	ASTM A 194 GR. 2H / ASTM A 193 GR. B7

**SCHEME FOR WET PILOT BASIC TRIM FOR DELUGE VALVE  
MODEL - ACV-FTV-100 FOR VERTICAL MOUNTING**

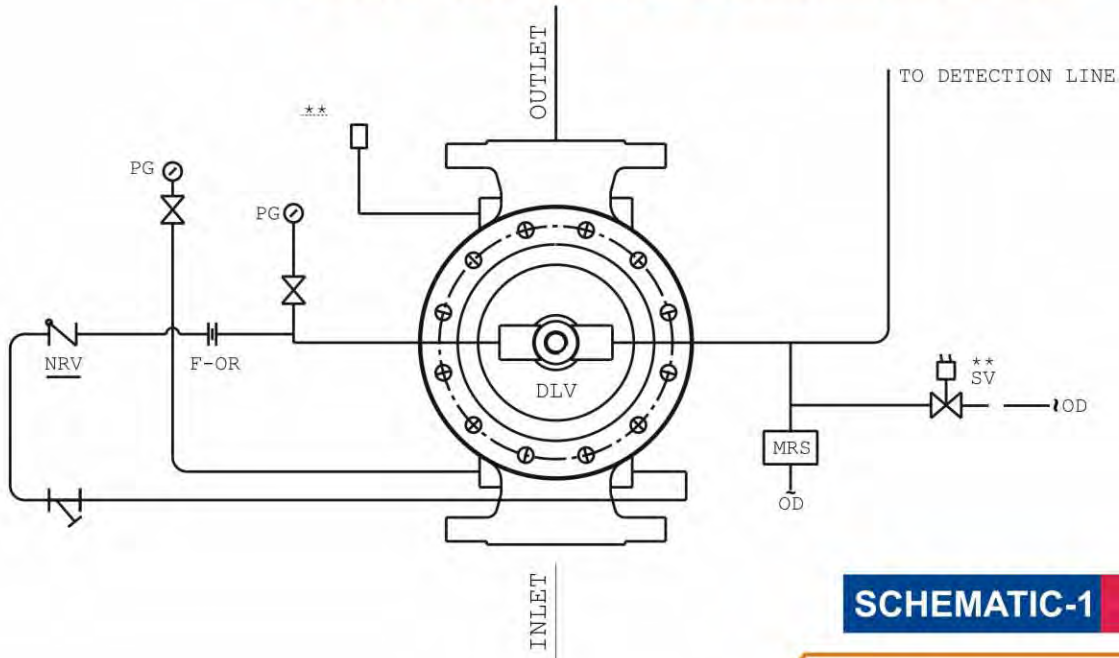

**SCHEMATIC-1 FTDLV-WPT**

**SCHEME FOR DRY PILOT BASIC TRIM FOR DELUGE VALVE  
MODEL - ACV-FTV-100 FOR VERTICAL MOUNTING**

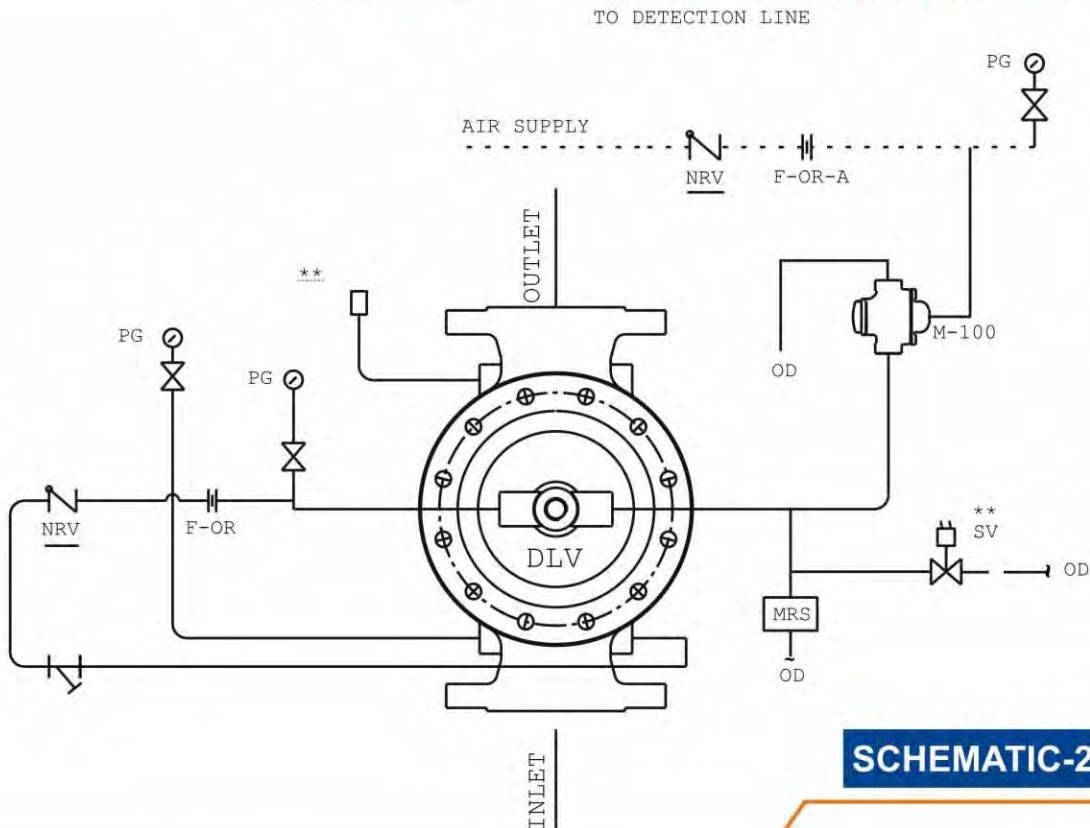

**SCHEMATIC-2 FTDLV-DPT**

- DLV - DELUGE VALVE
- SV - SOLENOID VALVE
- G - SPRINKLER ALARM GONG
- MRS - MANUAL RELEASE STATION
- F-OR - FIXED ORIFICE
- DV - DRAIN VALVE

- ⊗ - VALVE
- - BY USER
- \*\* - OPTIONAL
- ⌞ - STRAINER
- OD - OUT TO DRAIN

- M-100 - PILOT VALVE
- F-OR-A - FIXED ORIFICE
- PG - PRESSURE GAUGE
- NRV - NON RETURN VALVE
- ⌞ - LIFT CHECK VALVE
- PSW - WATER FLOW PRESSURE SWITCH

**SCHEME FOR WET PILOT BASIC TRIM FOR DELUGE VALVE  
MODEL - ACV-FTV-100 FOR VERTICAL MOUNTING**

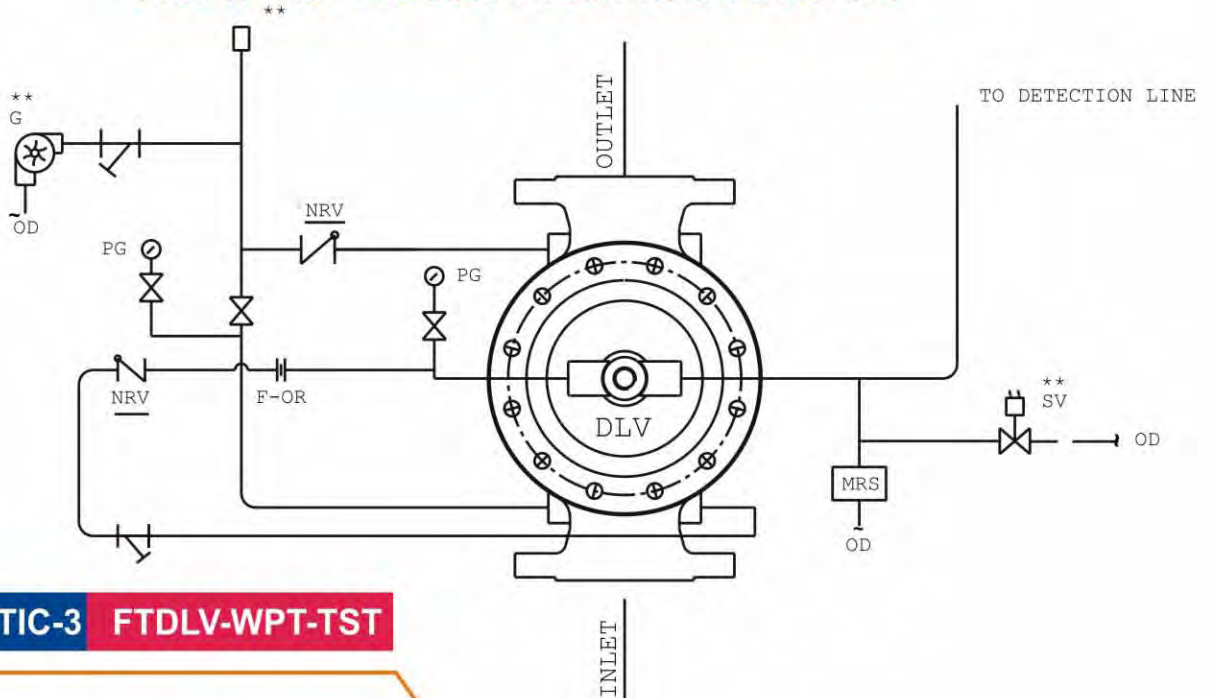

**SCHEMATIC-3 FTDLV-WPT-TST**

**SCHEME FOR DRY PILOT BASIC TRIM FOR DELUGE VALVE  
MODEL - ACV-FTV-100 FOR VERTICAL MOUNTING**

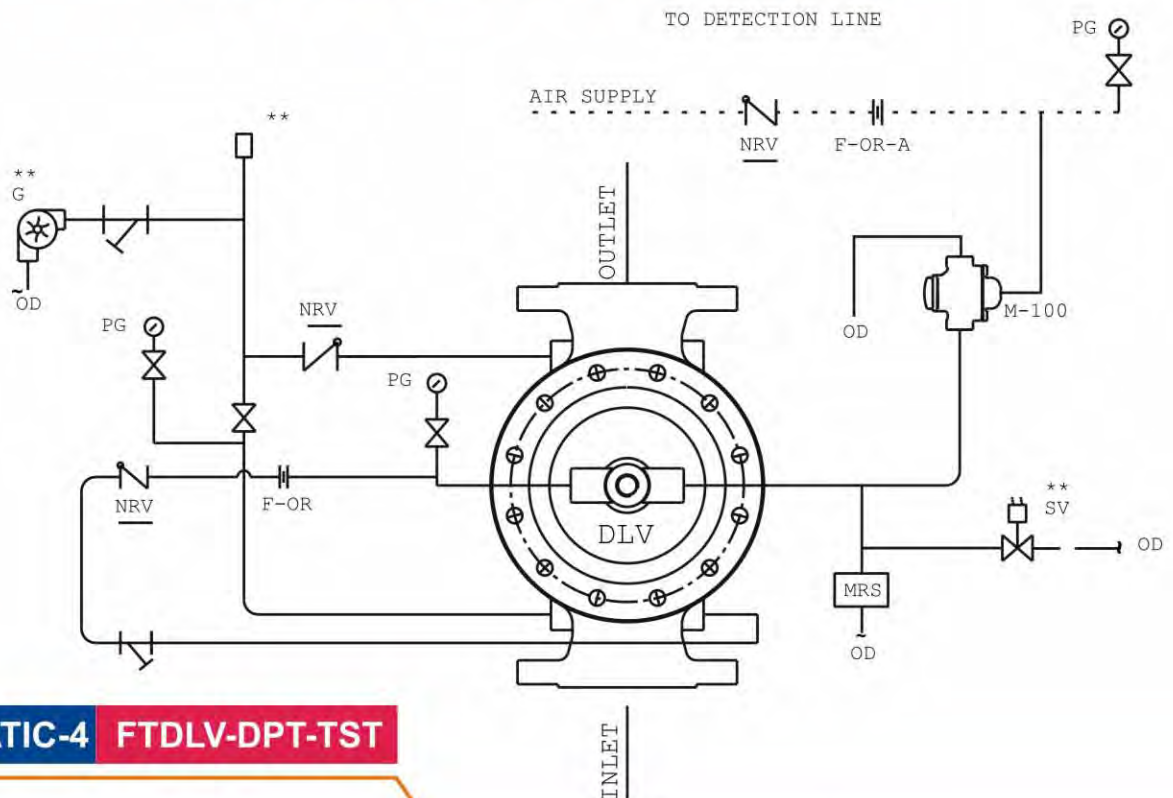

**SCHEMATIC-4 FTDLV-DPT-TST**

- DLV - DELUGE VALVE
- SV - SOLENOID VALVE
- G - SPRINKLER ALARM GONG
- MRS - MANUAL RELEASE STATION
- F-OR - FIXED ORIFICE
- DV - DRAIN VALVE

- ⊗ - VALVE
- - BY USER
- \*\* - OPTIONAL
- ⊗ - STRAINER
- OD - OUT TO DRAIN

- M-100 - PILOT VALVE
- F-OR-A - FIXED ORIFICE
- PG - PRESSURE GAUGE
- NRV - NON RETURN VALVE
- ⊗ - LIFT CHECK VALVE
- PSW - WATER FLOW PRESSURE SWITCH



**SCHEMATIC FOR WET PILOT BASIC TRIM FOR DELUGE VALVE  
MODEL - ACV-FTV-100 FOR VERTICAL MOUNTING**

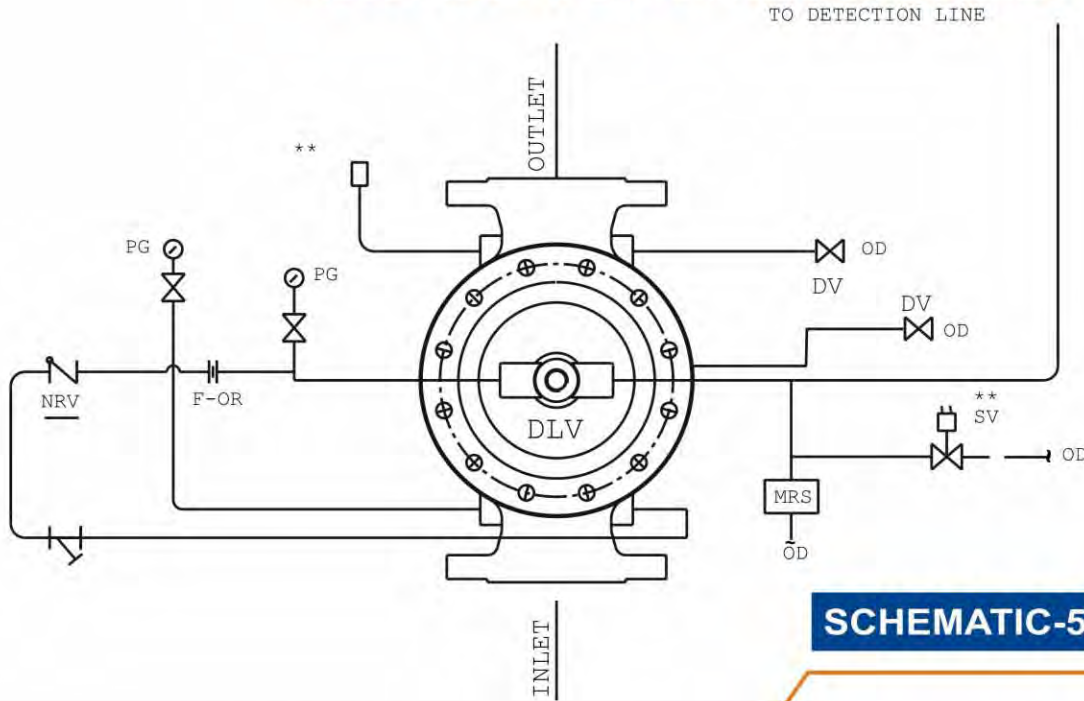

**SCHEMATIC-5 FTDLV-WPT-DRN**

**SCHEMATIC FOR DRY PILOT BASIC TRIM FOR DELUGE VALVE  
MODEL - ACV-FTV-100 FOR VERTICAL MOUNTING**

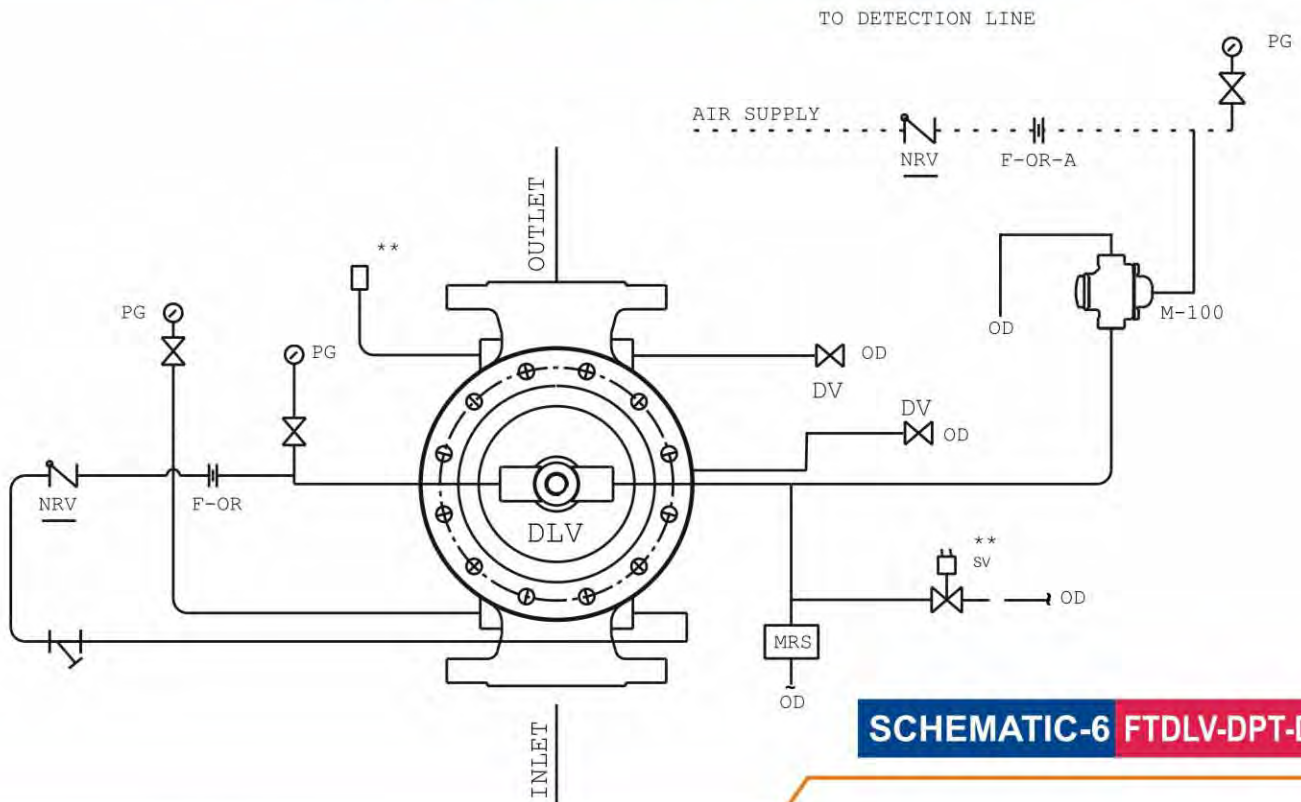

**SCHEMATIC-6 FTDLV-DPT-DRN**

- DLV - DELUGE VALVE
- SV - SOLENOID VALVE
- G - SPRINKLER ALARM GONG
- MRS - MANUAL RELEASE STATION
- F-OR - FIXED ORIFICE
- DV - DRAIN VALVE

- ⊗ - VALVE
- - BY USER
- \*\* - OPTIONAL
- ⌞ - STRAINER
- OD - OUT TO DRAIN

- M-100 - PILOT VALVE
- F-OR-A - FIXED ORIFICE
- PG - PRESSURE GAUGE
- NRV - NON RETURN VALVE
- ⌞ - LIFT CHECK VALVE
- PSW - WATER FLOW PRESSURE SWITCH

**SCHEMATIC FOR WET PILOT BASIC TRIM FOR DELUGE VALVE  
MODEL - ACV-FTV-100 FOR VERTICAL MOUNTING**

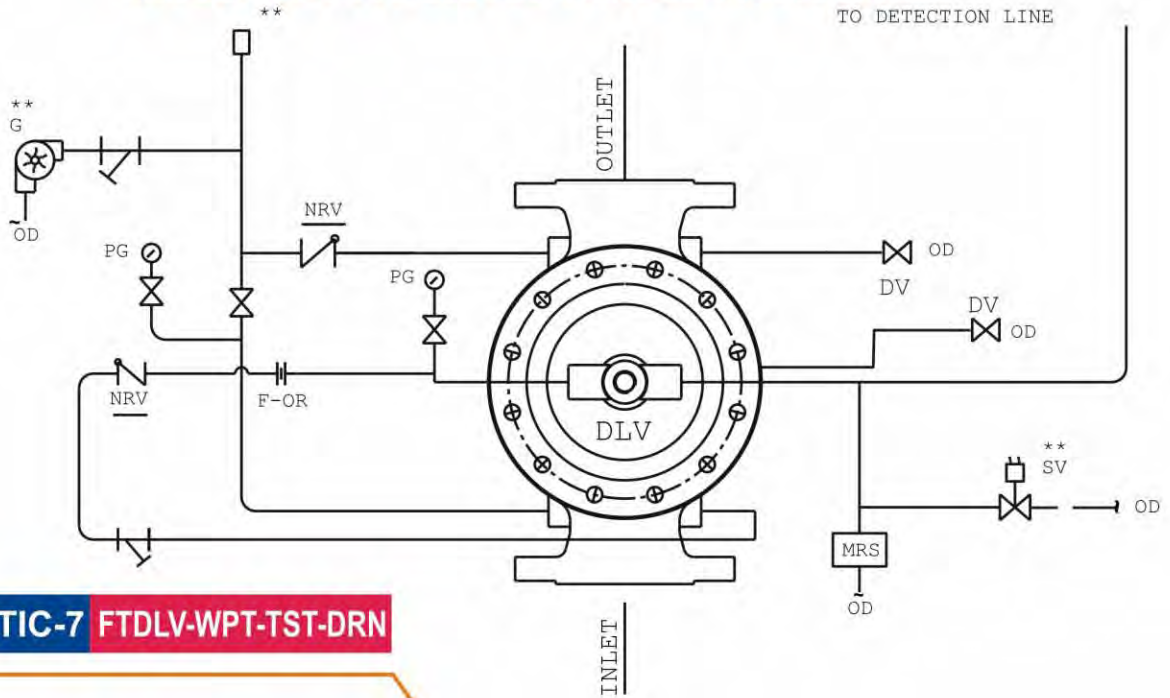

**SCHEMATIC-7 FTDLV-WPT-TST-DRN**

**SCHEMATIC FOR DRY PILOT BASIC TRIM FOR DELUGE VALVE  
MODEL - ACV-FTV-100 FOR VERTICAL MOUNTING**

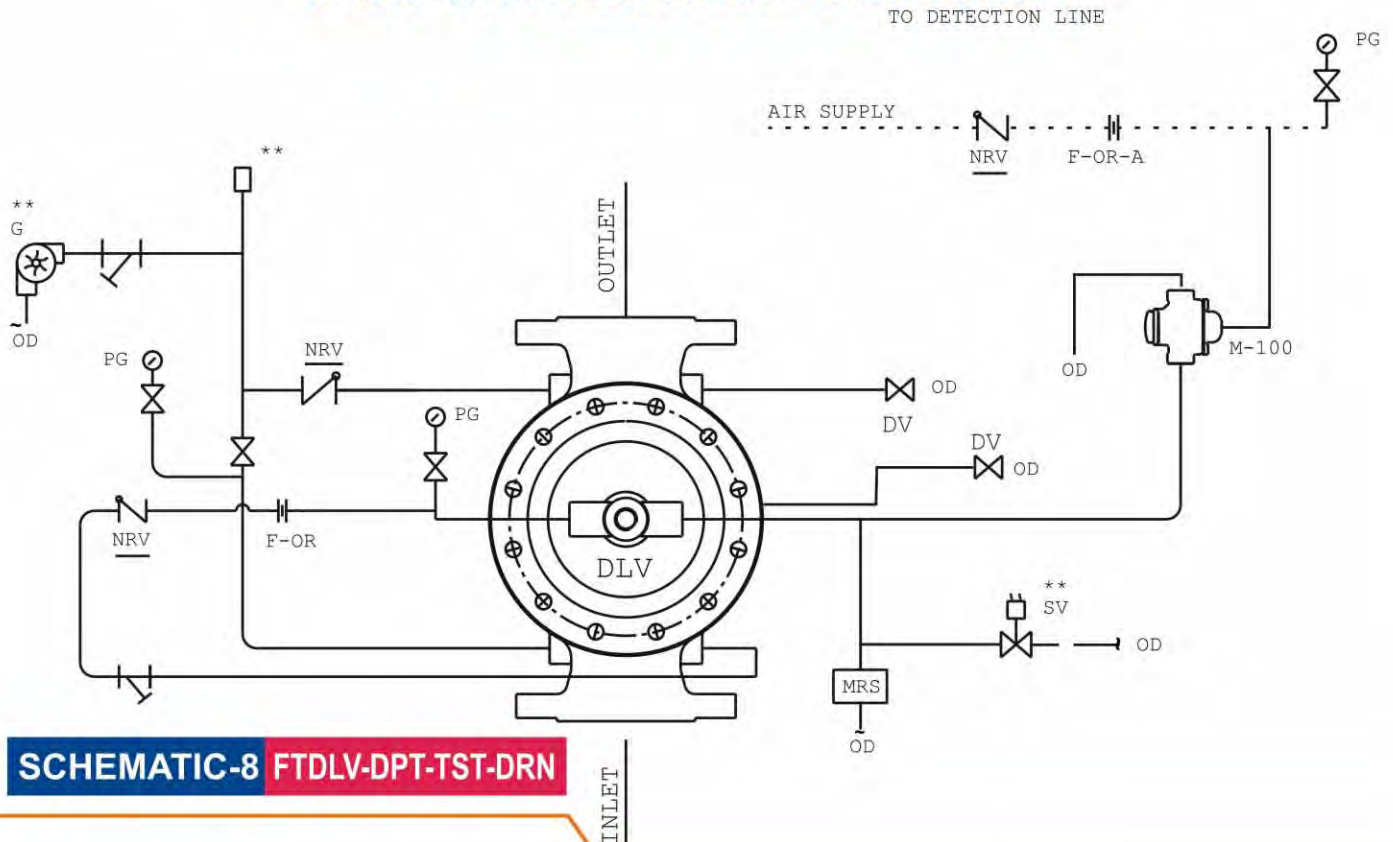

**SCHEMATIC-8 FTDLV-DPT-TST-DRN**

- DLV - DELUGE VALVE
- SV - SOLENOID VALVE
- G - SPRINKLER ALARM GONG
- MRS - MANUAL RELEASE STATION
- F-OR - FIXED ORIFICE
- DV - DRAIN VALVE

- ⊗ - VALVE
- - BY USER
- \*\* - OPTIONAL
- ⌞ - STRAINER
- OD - OUT TO DRAIN

- M-100 - PILOT VALVE
- F-OR-A - FIXED ORIFICE
- PG - PRESSURE GAUGE
- NRV - NON RETURN VALVE
- ⌞ - LIFT CHECK VALVE
- PSW - WATER FLOW PRESSURE SWITCH

**SCHEMATIC FOR WET PILOT BASIC TRIM FOR DELUGE VALVE  
MODEL - ACV-FTV-100 FOR VERTICAL MOUNTING**

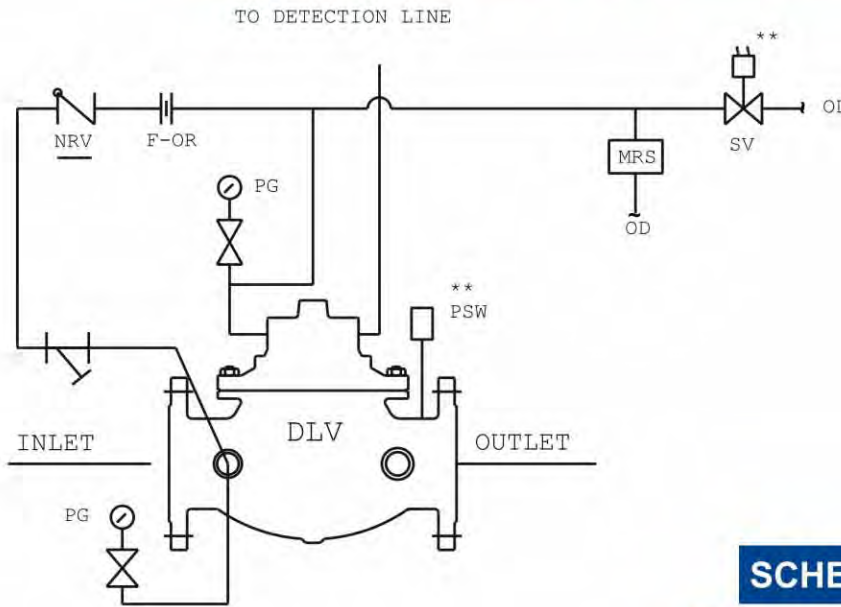

**SCHEMATIC-9 FTDLV-WPT**

**SCHEMATIC FOR DRY PILOT BASIC TRIM FOR DELUGE VALVE  
MODEL - ACV-FTV-100 FOR VERTICAL MOUNTING**

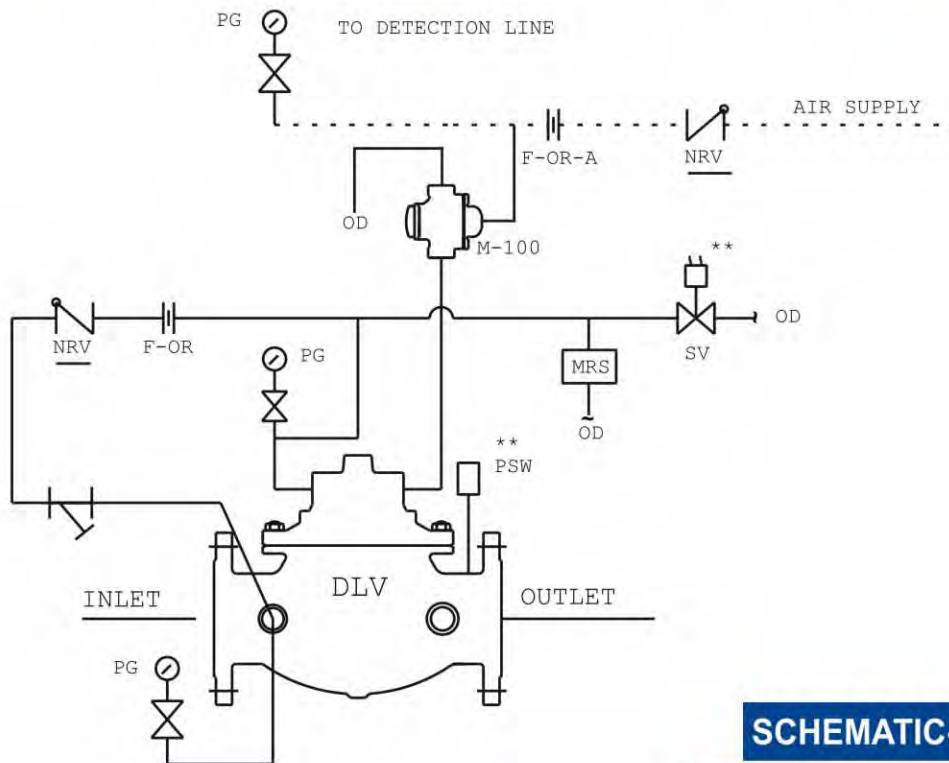

**SCHEMATIC-10 FTDLV-DPT**

- DLV - DELUGE VALVE
- SV - SOLENOID VALVE
- G - SPRINKLER ALARM GONG
- MRS - MANUAL RELEASE STATION
- F-OR - FIXED ORIFICE
- DV - DRAIN VALVE

- ⊗ - VALVE
- - BY USER
- \*\* - OPTIONAL
- ⊏ - STRAINER
- OD - OUT TO DRAIN

- M-100 - PILOT VALVE
- F-OR-A - FIXED ORIFICE
- PG - PRESSURE GAUGE
- NRV - NON RETURN VALVE
- ⊏ - LIFT CHECK VALVE
- PSW - WATER FLOW PRESSURE SWITCH

**SCHEMATIC FOR WET PILOT BASIC TRIM FOR DELUGE VALVE  
MODEL - ACV-FTV-100 FOR HORIZONTAL MOUNTING**

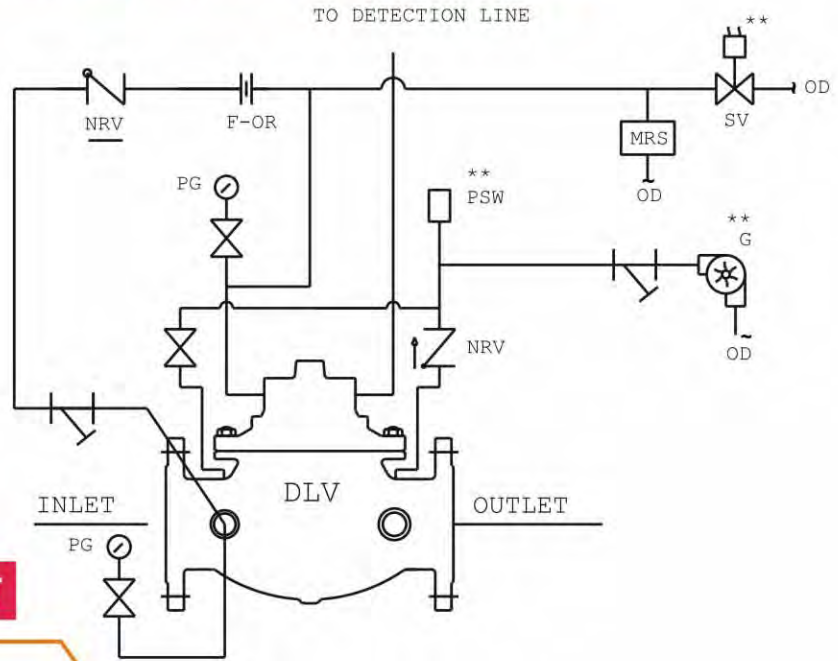

**SCHEMATIC-11 FTDLV-WPT-TST**

**SCHEMATIC FOR DRY PILOT BASIC TRIM FOR DELUGE VALVE  
MODEL - ACV-FTV-100 FOR HORIZONTAL MOUNTING**

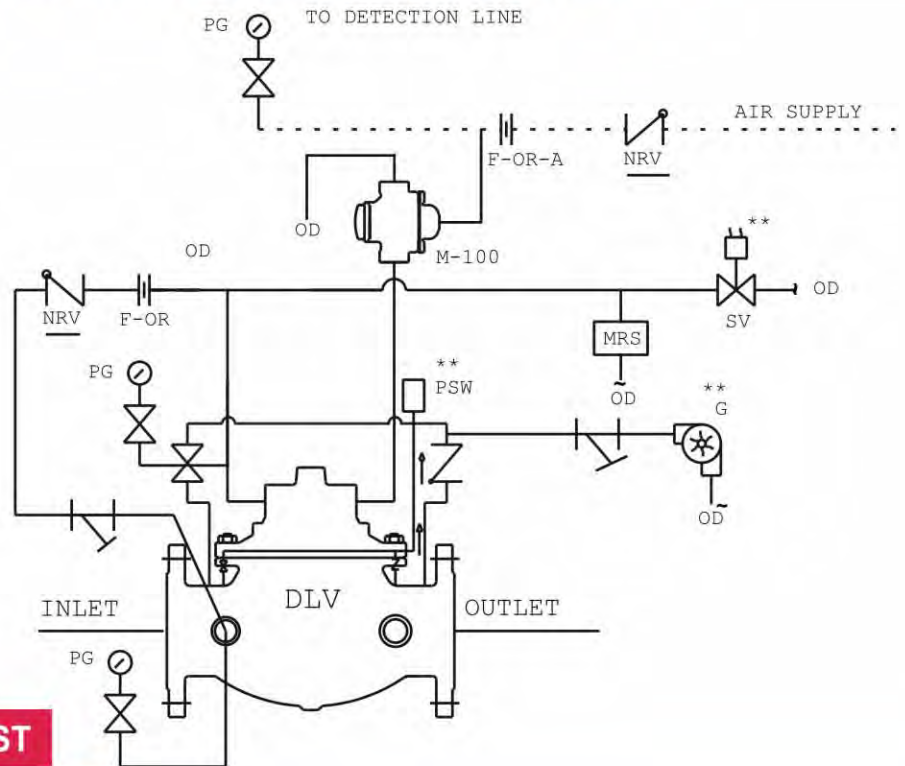

**SCHEMATIC-12 FTDLV-DPT-TST**

- DLV - DELUGE VALVE
- SV - SOLENOID VALVE
- G - SPRINKLER ALARM GONG
- MRS - MANUAL RELEASE STATION
- F-OR - FIXED ORIFICE
- DV - DRAIN VALVE

- ⊗ - VALVE
- - BY USER
- \*\* - OPTIONAL
- ⊏ - STRAINER
- OD - OUT TO DRAIN

- M-100 - PILOT VALVE
- F-OR-A - FIXED ORIFICE
- PG - PRESSURE GAUGE
- NRV - NON RETURN VALVE
- ⊏ - LIFT CHECK VALVE
- PSW - WATER FLOW PRESSURE SWITCH

**SCHEMATIC FOR WET PILOT BASIC TRIM FOR DELUGE VALVE  
MODEL - ACV-FTV-100 FOR HORIZONTAL MOUNTING**

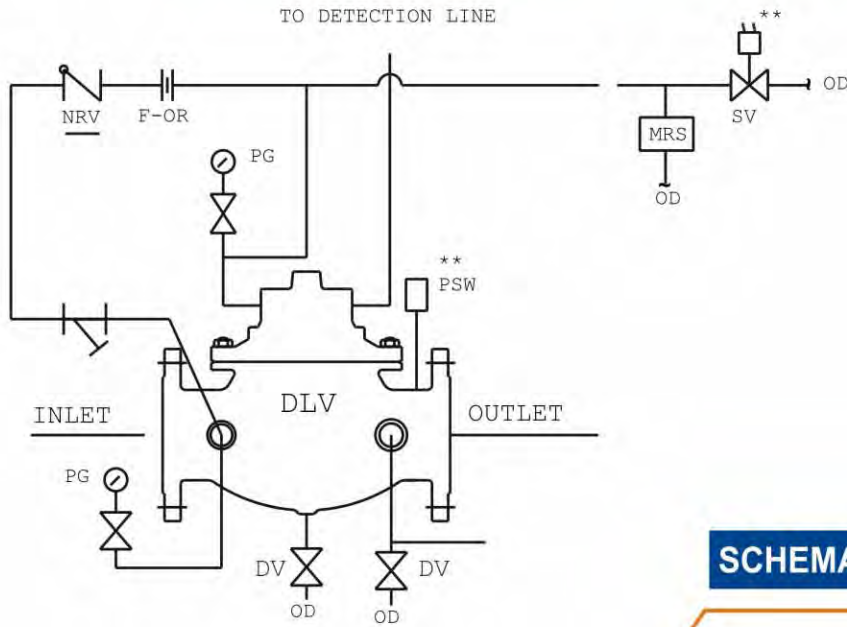

**SCHEMATIC-13 FTDLV-WPT-DRN**

**SCHEMATIC FOR DRY PILOT BASIC TRIM FOR DELUGE VALVE  
MODEL - ACV-FTV-100 FOR HORIZONTAL MOUNTING**

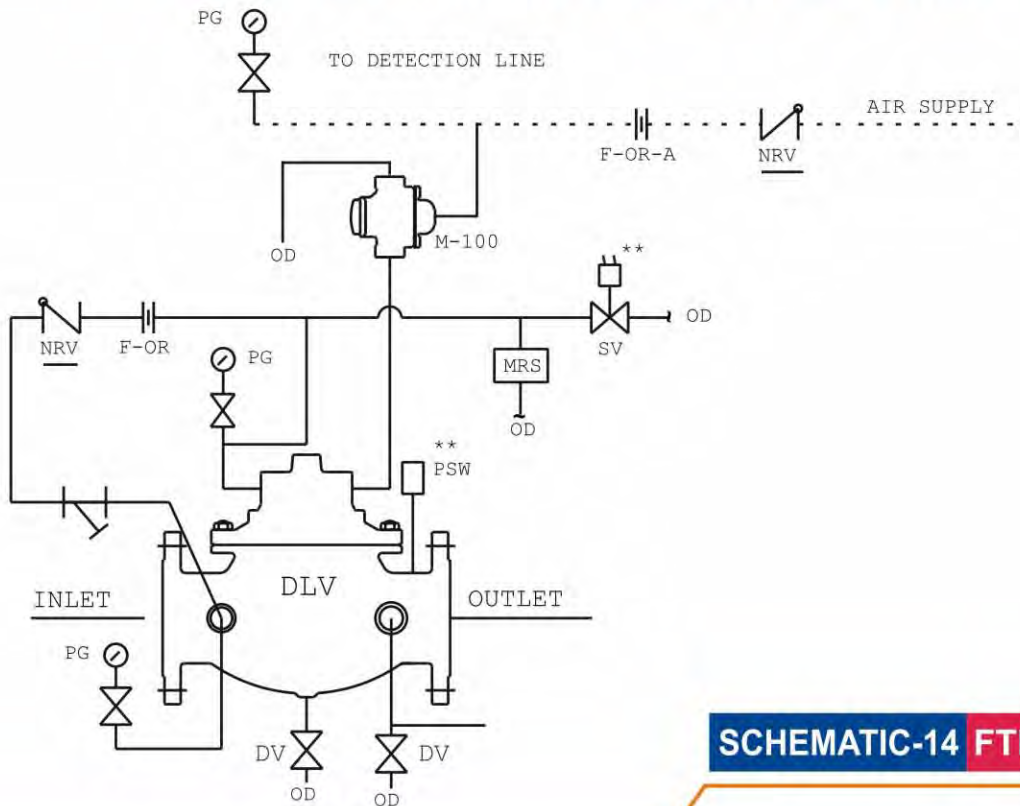

**SCHEMATIC-14 FTDLV-DPT-DRN**

- DLV - DELUGE VALVE
- SV - SOLENOID VALVE
- G - SPRINKLER ALARM GONG
- MRS - MANUAL RELEASE STATION
- F-OR - FIXED ORIFICE
- DV - DRAIN VALVE

- ⊗ - VALVE
- - BY USER
- \*\* - OPTIONAL
- ⊏ - STRAINER
- OD - OUT TO DRAIN

- M-100 - PILOT VALVE
- F-OR-A - FIXED ORIFICE
- PG - PRESSURE GAUGE
- NRV - NON RETURN VALVE
- ⊏ - LIFT CHECK VALVE
- PSW - WATER FLOW PRESSURE SWITCH

**SCHEMATIC FOR WET PILOT BASIC TRIM FOR DELUGE VALVE  
MODEL - ACV-FTV-100 FOR HORIZONTAL MOUNTING**

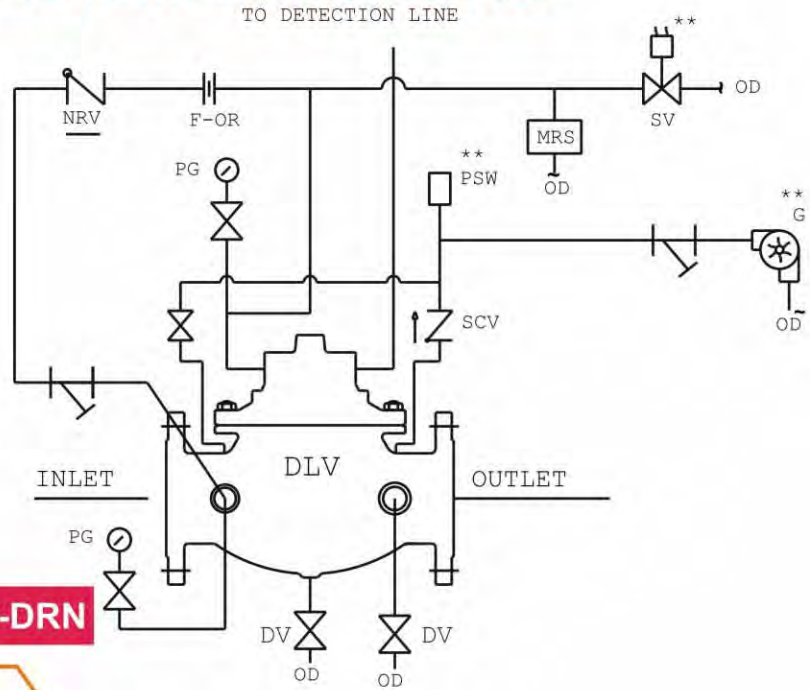

**SCHEMATIC-15 FTDLV-WPT-TST-DRN**

**SCHEMATIC FOR DRY PILOT BASIC TRIM FOR DELUGE VALVE  
MODEL - ACV-FTV-100 FOR HORIZONTAL MOUNTING**

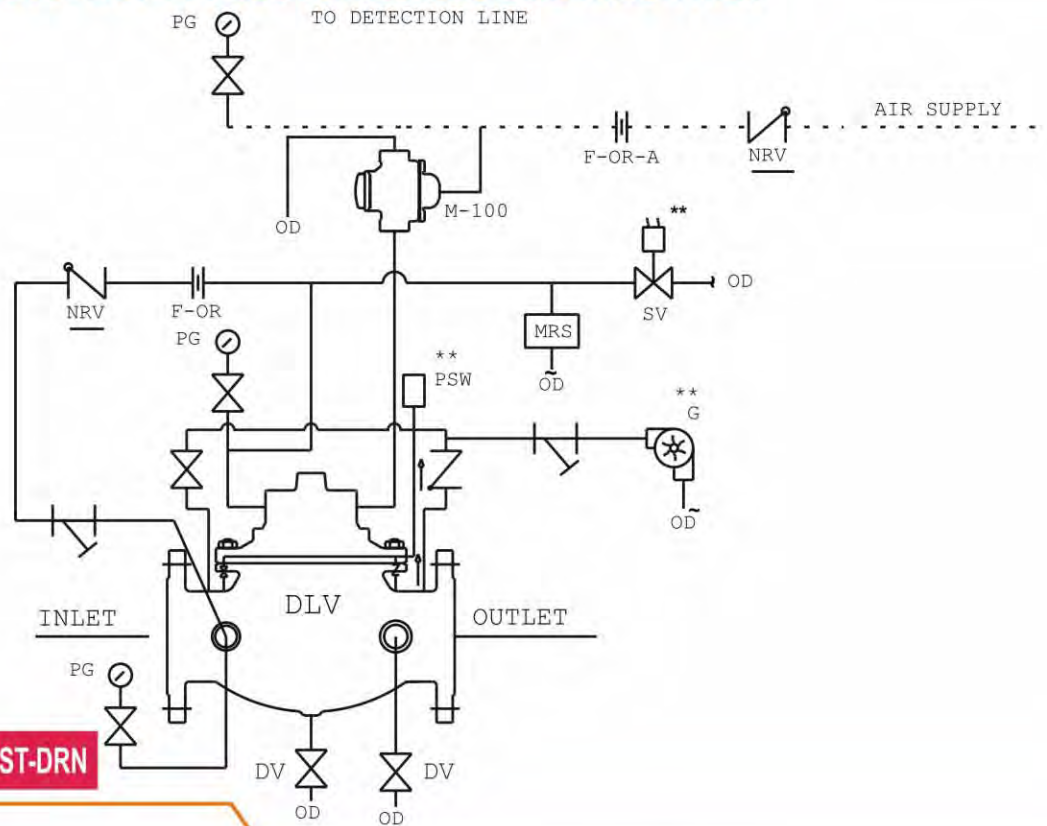

**SCHEMATIC-16 FTDLV-DPT-TST-DRN**

DLV - DELUGE VALVE  
SV - SOLENOID VALVE  
G - SPRINKLER ALARM GONG  
MRS - MANUAL RELEASE STATION  
F-OR - FIXED ORIFICE  
DV - DRAIN VALVE

⊗ - VALVE  
--- - BY USER  
\*\* - OPTIONAL  
S - STRAINER  
OD - OUT TO DRAIN

M-100 - PILOT VALVE  
F-OR-A - FIXED ORIFICE  
PG - PRESSURE GAUGE  
NRV - NON RETURN VALVE  
L - LIFT CHECK VALVE  
PSW - WATER FLOW PRESSURE SWITCH

## SPRINKLER HEIGHT LIMITATION

### ACV FTV 100 - 50NB

Maximum Pilot Line Height, FEET

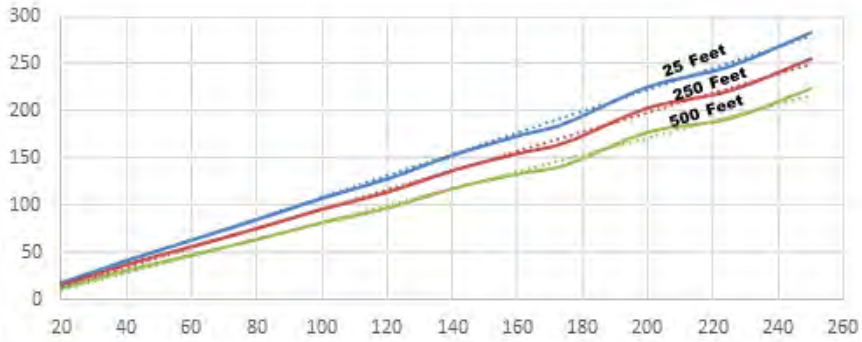

System Supply Pressure, PSI

### ACV FTV 100 - 65NB

Maximum Pilot Line Height, FEET

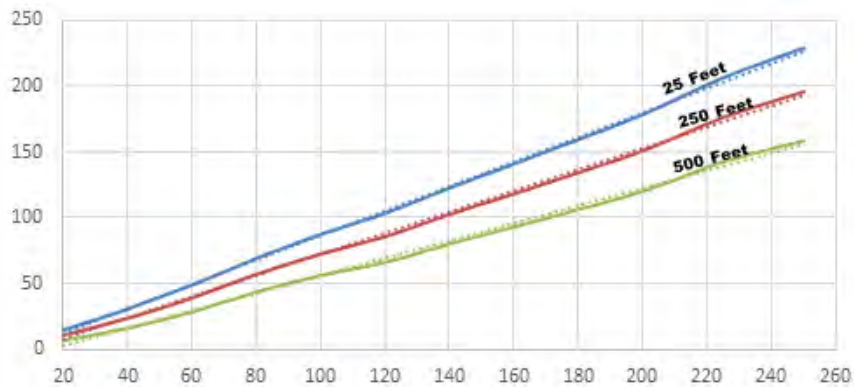

System Supply Pressure, PSI

## SPRINKLER HEIGHT LIMITATION

### ACV FTV 100 - 80NB

Maximum Pilot Line Height, FEET

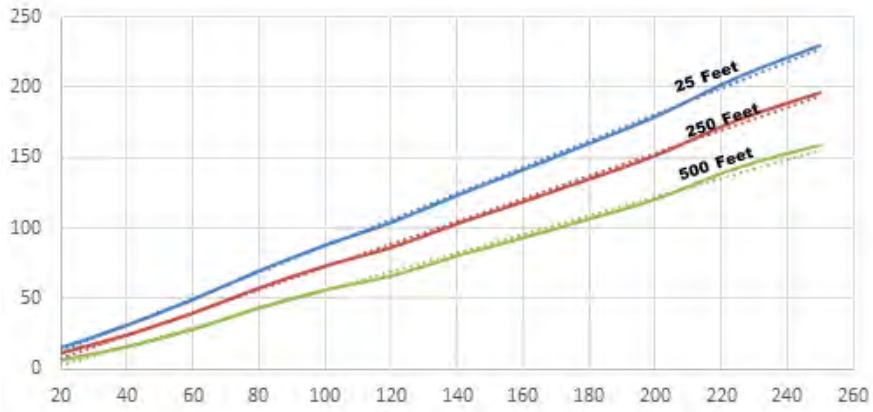

System Supply Pressure, PSI

### ACV FTV 100 - 100NB

Maximum Pilot Line Height, FEET

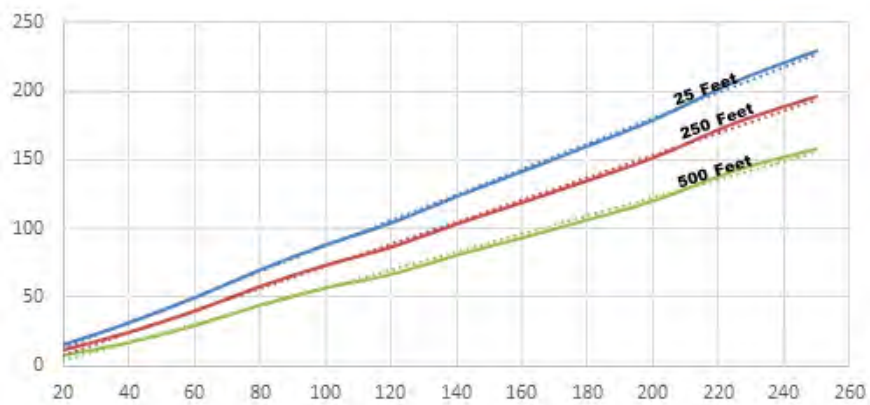

System Supply Pressure, PSI



## SPRINKLER HEIGHT LIMITATION

### ACV FTV 100 - 150NB

Maximum Pilot Line Height, FEET

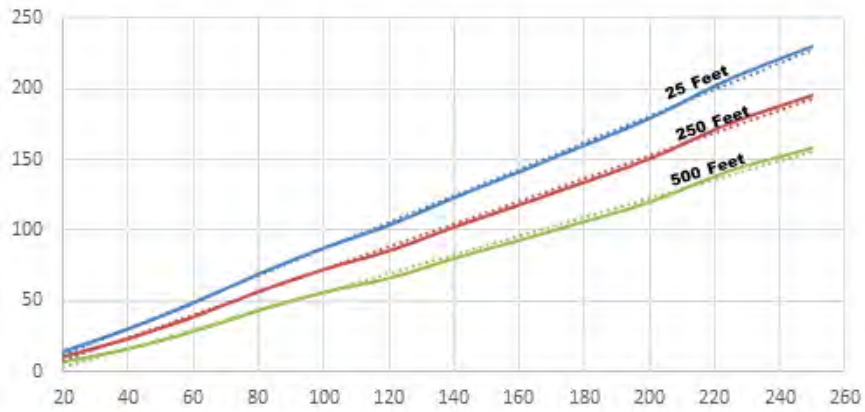

System Supply Pressure, PSI

### ACV FTV 100 - 200NB

Maximum Pilot Line Height, FEET

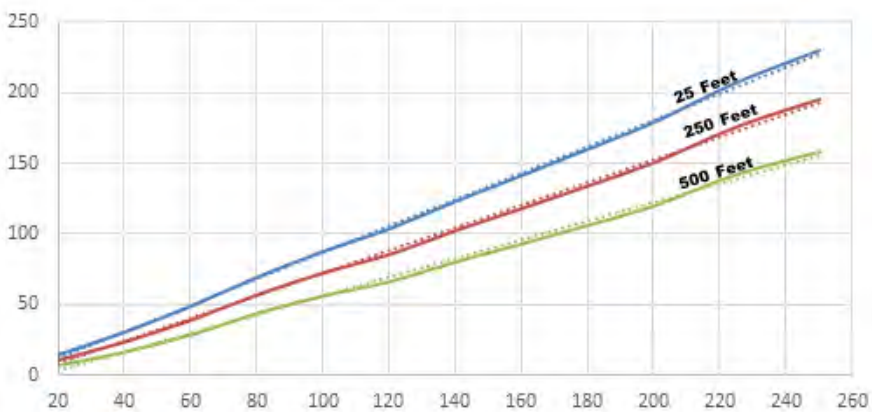

System Supply Pressure, PSI

**ACV FTV 100 - 250NB**

Maximum Pilot Line Height, FEET

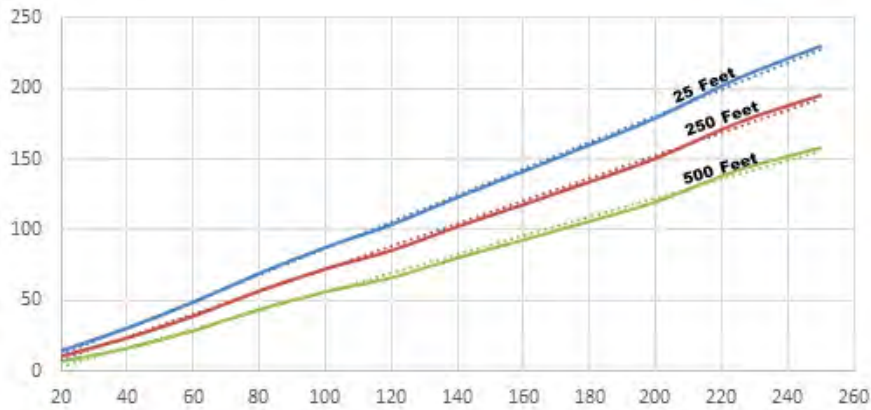

System Supply Pressure, PSI

**NORMAL PRESSURE LOSS v/s FLOW**

NORMAL PRESSURE LOSS IN PSI

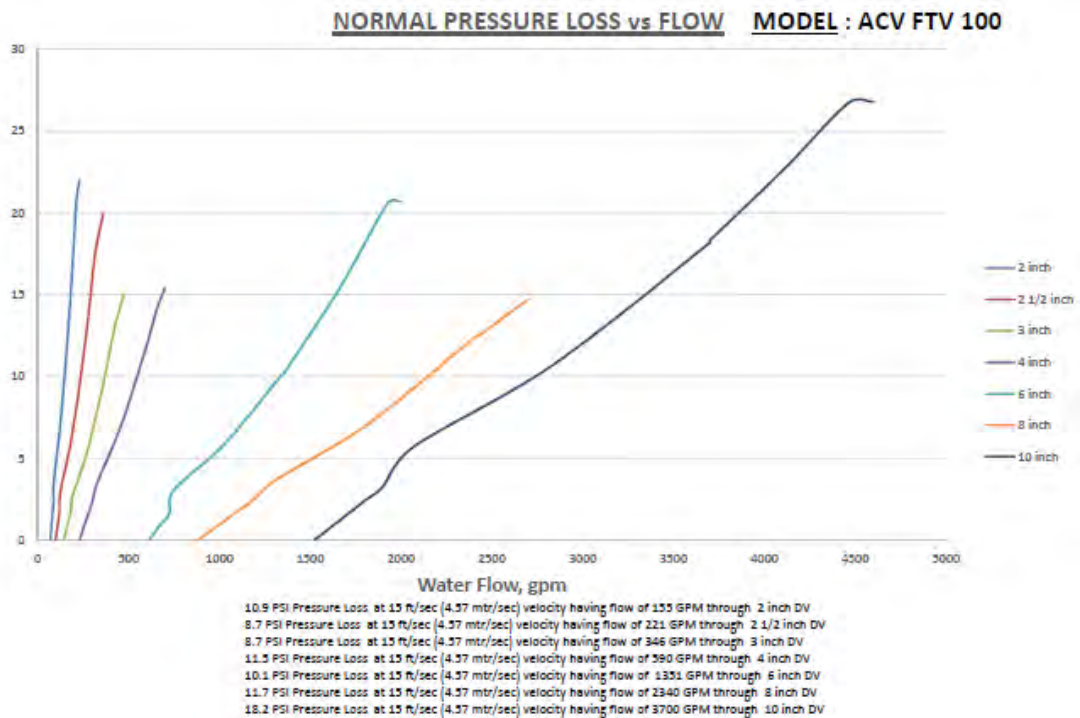

FLOW RATE IN GPM

## DELUGE VALVE SKID

### PRODUCT OVERVIEW

Flowage make Deluge Valve SKID having models integrated pre-assembled open skid mounted of frame. Other model having Pre-assembly with pre-wired and water connection with flanges in close cabinet. This Skid also having inlet outlet and bypass line with accessories like pressure switches solenoid and drain facilities is cabinet mounted.



- UL approved Deluge valve is installed in the Skid
- Isolation butterfly valves in inlet and outlet and bypass line
- Pressure switch, solenoid valve mounted, pre-wired & terminated available in junction box

### TECHNICAL DATA

- Deluge Valve Skid Model - FTV ACV 300
- Size - 50, 80, 100, 150 & 200 mm (2", 3", 4", 6" & 8")
- Actuation type - Dry Pilot, Wet Pilot, Electric Release, Manual Release Trim, Test Alarm
- M.O.C. - Cast Iron, Cast Steel, Alloy Steel Construction
- Service pressure - 1.4 to 12 bar (20 to 175 PSI)
- Mounting - Horizontal
- Flanged connection dimensions to ANSI B 16.5
- Finish - RAL 3000 (Red Colour)
- UL Under Process
- Ordering Information - Size, Model, Trim Type with specified solenoid voltage.

\* For more details you can contact us :

# CLIENTS LIST

 हिन्दुस्तान पेट्रोलियम <b>HP</b>	 एन एच पी सी <b>NHPC</b>	 पावरग्रिड	 बी एच ई एल <b>BHEL</b>	 इंडियन ऑयल IndianOil	 Bharat Petroleum
 Reliance Industries Limited	 ओ एन जी सी <b>ONGC</b>	 <b>UltraTech</b> CEMENT The Engineer's Choice	 <b>JINDAL</b> STEEL & POWER	 ADITYA BIRLA HINDALCO	 vedanta
 SESA GOA	 गैल <b>GAIL</b>	 ADANI	 ALSTOM	 TATA TATA PROJECTS LIMITED	 ESSAR
 इसरो isro	 Government of India Department of Atomic Energy	 <b>DSCL</b> DCM SHRIRAM CONSOLIDATED LTD	 <b>JAYPEE</b> GROUP	 सेल SAIL	 ऑयल इंडिया लिमिटेड Oil India Limited
 GNFC	 KSK	 VIZAG STEEL	 WABAG	 STERLITE INDUSTRIES (INDIA) LIMITED	 JSW
 ABB	 Hindustan Unilever Limited	 GE	 NAGARJUNA GROUP	 Kinlokar	 LUPIN
 THERMAX	 JK PAPER LTD.	 JGC PHILIPPINES, INC.	 JK LAKSHMI CEMENT LTD.	 ORIENT CEMENT A Commitment To Quality	 Petrofac
 MOL	 RANBAXY LABORATORIES LIMITED	 GUJARAT STATE FERTILIZERS & CHEMICALS LTD. An ISO-Certified Company	 ADITYA BIRLA GROUP	 ADITYA BIRLA GRASIM BHIWANI TEXTILES	 UltraTech
 TATA CHEMICALS LIMITED	 TATA TEA	 TIMCO	 torrent	 UB GROUP	 ADM
 CADILA PHARMACEUTICALS LIMITED	 bilt	 CONCORD Biotech for Mankind...	 SUN PHARMA	 Glenmark A new way for a new world	 Garden* VARELI
 INDORAMA VENTURES	 amneal PHARMACEUTICALS	 H.P.C. (Hindustan Paper Corp. Ltd.)	 HNG	 Anil Excellence Defined	 BHUSHAN



## **FLOW-TEK VALVES & CONTROLS INC**

PLOT NO. 172-173, ROAD NO. 4,  
KATHWADA G.I.D.C., KATHWADA,  
AHMEDABAD - 382 430. GUJARAT, INDIA.

Phone : 079-22900219, 079-22900220,

Mobile: +91 – 9824080899, 9824539702.

E-mail: [info@flowagevalves.com](mailto:info@flowagevalves.com); [hemal21386@gmail.com](mailto:hemal21386@gmail.com)