

# SAFETY RELIEF VALVE

MODEL NO. - HP-600

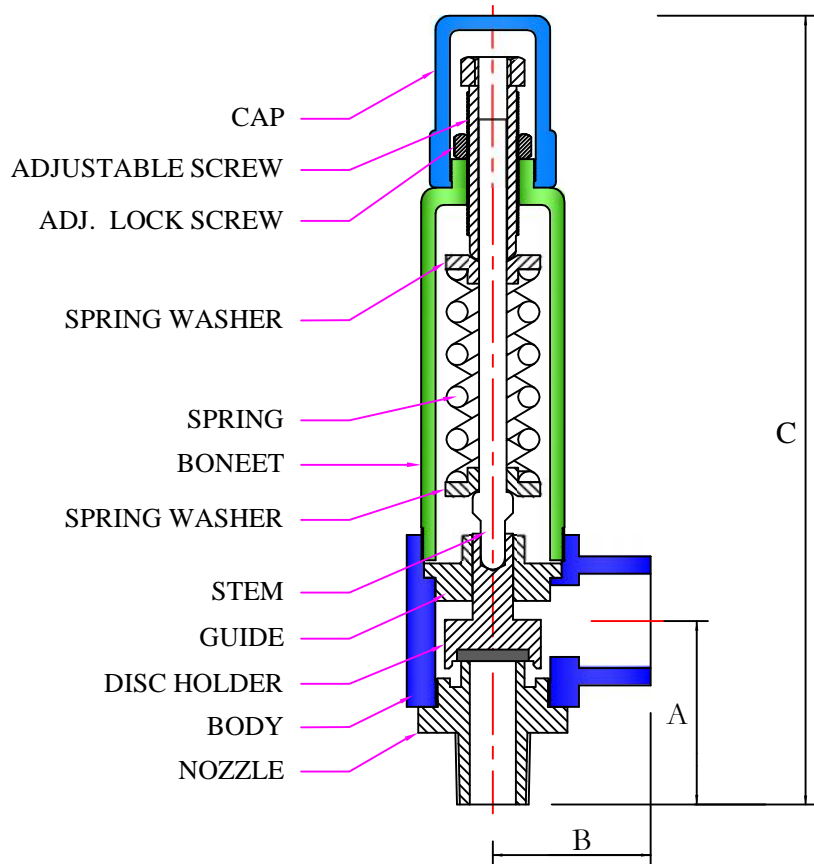

## **TECHNICAL SPECIFICATION :**

Built in conformance to ASME Code section / API for Air, Gas, Steam and Liquid Service.

- Valve Size :- 1/4" to 2" NPT/BSP
- Pressure Range :- 0 to 10000 PSIG
- Material :- C.S/ CF3/ CF3M/ CF8/ CF8M/ Alloy Steel



## FLOW-TEK VALVES & CONTROLS INC

PLOT NO: 172-173, ROAD NO. 4, G.I.D.C.,  
KATHWADA, AHMEDABAD - 382430  
(M) : 09824080899, 09824539702  
PHONE : (079) 22900220, 22900219  
E-MAIL : info@flowagevalves.com, hemal21386@gmail.com  
url : www.delugecontrolvalve.com, www.flowagevalves.com  
AN ISO 9001:2008 CERTIFIED COMPANY